

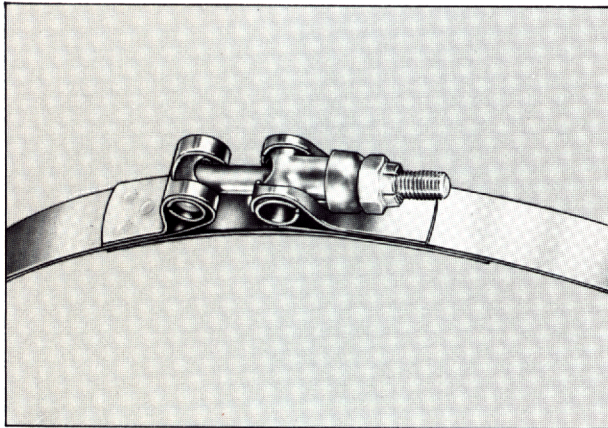

AEROQUIP STAINLESS STEEL STRAPS



Straps

Aeroquip designed straps are made for use on many tie-down and equipment holding applications.

Minimum radius "R" is that recommended to be used at the corners of objects. The latch should be located about the curvature when possible rather than on the flat. Ample wrench clearance should be provided at the nut end of the latch. Loop end types are designed for use with clevis pins or bolts, the slotted loop ends are for use with eye bolts and pins.

Bolts

All bolts have UNJF-3A Threads

Important Drawing Note

T-Bolts are shipped either on the trunnion or T-Bolt side of the latch depending on the latch assembly, therefore, care must be taken to pair even (or odd) series numbers so the complete unit will contain a T-Bolt.

Example: 2305 & 2331 = Quick coupler latch with one plain end strap and one loop end strap.

Nuts

Nuts for use with alloy steel T-Bolts

Nut Code		Description	Recommended Use
New	Old		
S	S	AN365 self-locking cadmium plated steel with non metallic insert.	For applications up to +250°F. (+121°C.)
SH	SH	AN363 self-locking high temperature cadmium plated steel nut.	For applications up to +550°F. (+287°C.)

Nuts for use with stainless steel T-Bolts

D	ST	Aeroquip MS103C plain hex; silver plated stainless steel with lock-wire hole.	For applications up to +800°F. (+426°C.)
M	none	ESNA Z1200J self-locking high temperature silver plated stainless steel special.	For applications up to +1200°F. (+648°C.)

Strength Data

Band Material—MIL-S-5059 Comp 301 1/2-Hard Stainless Steel
Band Yield Strength, Lbs.

Gage	Width in Hundredths Inches							
	62	75	88	100	112	125	138	150
.020	1364	1650	1936	2200				
.025		2062	2420	2750	3090	3438	3795	4125

Bolt Material:

A286 CRES per AMS 5732/5737

Bolt Strength:

10-32 T-Bolt Yield = 3200 lbs.

1/4-28 T-Bolt Yield = 5824 lbs.

AN Pin-Flat Head (Clevis) in Double Shear

3/16 = 4140 lbs. 1/4 = 7360 lbs. 3/8 = 16575 lbs.

AN Eye bolt—Yield Strength:

AN42 (10-32 Bolt—3/16 Pin) = 800 lbs.

AN43 (1/4-28 Bolt—3/16 Pin) = 1880 lbs.

AN44 (5/16-24 Bolt—1/4 Pin) = 3000 lbs.

AN46 (3/8-24 Bolt—3/8 Pin) = 5375 lbs.

STAINLESS STEEL STRAP ENGINEERING DATA

Loop End / T-Bolt Latch

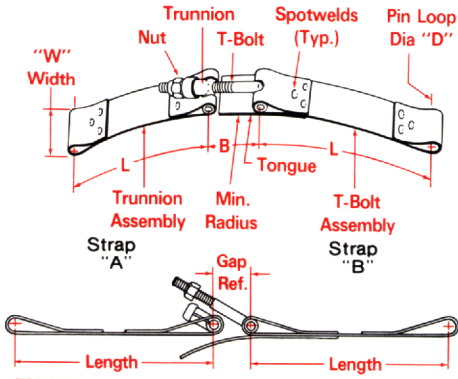

All dimensions in inches

Series Number		Loop Dia. D	T-Bolt Size	T-Bolt Length	Gage	Min. Radius R	Gap Ref. B	Assembly Adjustment Range		Min. Length L
Strap "A"	Strap "B"							+	-	
2330	2334	.187	10-32	1.750	.020	1.000	.813	.219	.406	2.630
	2338	.187	10-32	2.250	.020	1.500	1.188	.250	.750	2.630
2332	2336	.250	10-32	1.750	.020	1.000	.813	.219	.406	2.630
	2340	.250	10-32	2.250	.020	1.500	1.188	.250	.750	2.630
2430	2434	.250	1/4-28	2.500	.025	1.250	1.188	.281	.656	3.250
	2438	.250	1/4-28	3.500	.025	3.500	2.000	.500	1.500	3.250
2432	2436	.375	1/4-28	2.500	.025	1.250	1.188	.281	.656	3.250
	2440	.375	1/4-28	3.500	.025	3.500	2.000	.500	1.500	3.250

Loop End / Quick Coupler Latch

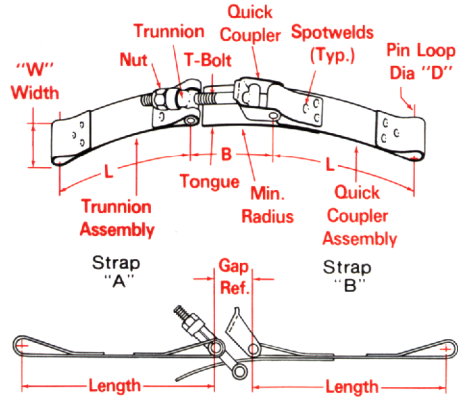

All dimensions in inches.

Series Number		Loop Dia. D	T-Bolt Size	T-Bolt Length	Gage	Min. Radius R	Gap Ref. B	Assembly Adjustment Range		Min. Length L
Strap "A"	Strap "B"							+	-	
2331	2339	.187	10-32	1.750	.020	1.000	1.313	.219	.406	2.630
	2335	.187	10-32	2.250	.020	1.500	1.688	.250	.750	2.630
2333	2341	.250	10-32	1.750	.020	1.000	1.313	.219	.406	2.630
	2337	.250	10-32	2.250	.020	1.500	1.688	.250	.750	2.630
2431	2439	.250	1/4-28	2.500	.025	2.000	1.813	.188	.750	3.250
	2435	.250	1/4-28	3.500	.025	3.500	2.563	.500	1.500	3.250
2433	2441	.375	1/4-28	2.500	.025	2.000	1.813	.188	.750	3.250
	2437	.375	1/4-28	3.500	.025	3.500	2.563	.500	1.500	3.250

Loop End Slotted / T-Bolt Latch

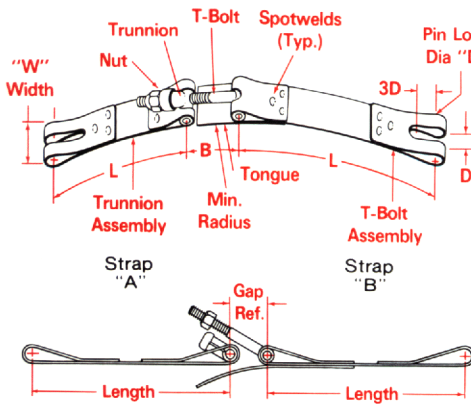

All dimensions in inches.

Series Number		Loop Dia. D	T-Bolt Size	T-Bolt Length	Gage	Min. Radius R	Gap Ref. B	Assembly Adjustment Range		Min. Length L
Strap "A"	Strap "B"							+	-	
2360	2364	.187	10-32	1.750	.020	.625	.813	.219	.406	3.120
	2368	.187	10-32	2.250	.020	1.500	1.188	.250	.750	3.120
2362	2366	.250	10-32	1.750	.020	.625	.813	.219	.406	3.120
	2370	.250	10-32	2.250	.020	1.500	1.188	.250	.750	3.120
2460	2464	.250	1/4-28	2.500	.025	1.250	1.188	.281	.656	3.440
	2468	.250	1/4-28	3.500	.025	3.500	2.000	.500	1.500	3.440
2462	2466	.375	1/4-28	2.500	.025	1.250	1.188	.281	.656	3.440
	2470	.375	1/4-28	3.500	.025	3.500	2.000	.500	1.500	3.440

Loop End Slotted / Quick Coupler Latch

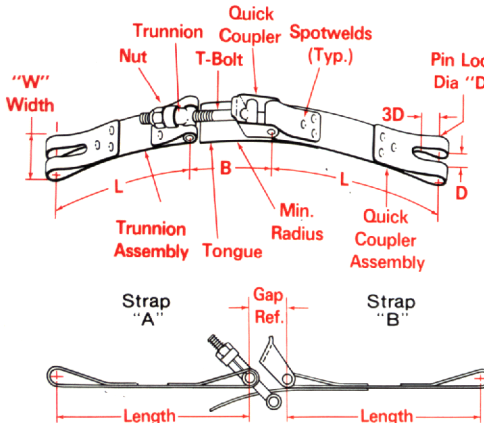

All dimensions in inches.

Series Number		Loop Dia. D	T-Bolt Size	T-Bolt Length	Gage	Min. Radius R	Gap Ref. B	Assembly Adjustment Range		Min. Length L
Strap "A"	Strap "B"							+	-	
2361	2369	.187	10-32	1.750	.020	.625	.813	.219	.406	3.120
	2365	.187	10-32	2.250	.020	1.500	1.188	.250	.750	3.120
2363	2371	.250	10-32	1.750	.020	.625	.813	.219	.406	3.120
	2367	.250	10-32	2.250	.020	1.500	1.188	.250	.750	3.120
2461	2469	.250	1/4-28	2.500	.025	1.250	1.188	.281	.656	3.440
	2465	.250	1/4-28	3.500	.025	3.500	2.000	.500	1.500	3.440
2463	2471	.375	1/4-28	2.500	.025	1.250	1.188	.281	.656	3.440
	2467	.375	1/4-28	3.500	.025	3.500	2.000	.500	1.500	3.440

Plain End/T-Bolt Latch

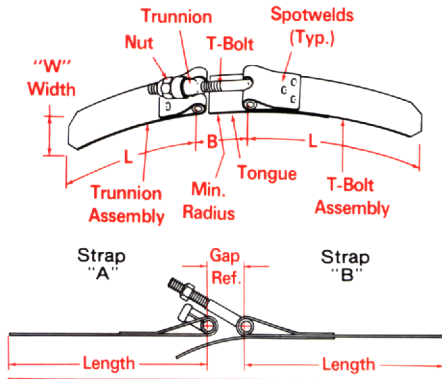

All dimensions in inches

Series Number		T-Bolt Size	T-Bolt Length	Gage	Min. Radius R	Gap Ref. B	Assembly Adjustment Range		Min. Length L
Strap "A"	Strap "B"						+	-	
2300	2302	10-32	1.750	.020	.625	.813	.219	.406	1.870
	2304	10-32	2.250	.020	1.500	1.188	.250	.750	1.870
2400	2402	1/4-28	2.500	.025	1.250	1.188	.282	.656	1.870
	2404	1/4-28	3.500	.025	3.500	2.000	.500	1.500	1.870

Plain End/Quick Coupler Latch

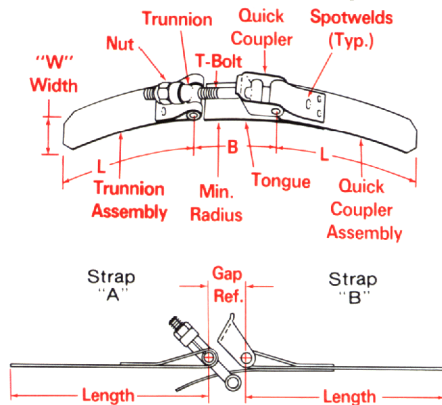

All dimensions in inches

Series Number		T-Bolt Size	T-Bolt Length	Gage	Min. Radius R	Gap Ref. B	Assembly Adjustment Range		Min. Length L
Strap "A"	Strap "B"						+	-	
2301	2305	10-32	1.750	.020	1.000	1.313	.219	.406	1.870
	2303	10-32	2.250	.020	1.500	1.688	.250	.750	1.870
2401	2405	1/4-28	2.500	.025	2.000	1.813	.188	.750	1.870
	2403	1/4-28	3.500	.025	3.500	2.563	.500	1.500	1.870

ORDERING INFORMATION

*Part Number Example:

2302 - 62 - 550 S

Series Number _____

T-Bolt Code: _____

A, C or — = A286 T-bolt

"W" Width (In hundredth inches: 100 = 1 inch) _____

Pad: _____

— = No Pad

P = .060 Thick Cork-Rubber Pad

Per MIL-T-6841 (Example: 2302-62P550S)

"L" Length (In hundredth inches: 100 = 1.00 inch) _____

Nut (See cover for coding) _____

NOTES:

1. Specify all widths in one of the following available sizes:
"W"—2300 Series/52, 62, 75, 88, 100, 112, 138, 150, 162, 175, 188, 200, 212, 225.
"W"—2400 Series/75, 88, 100, 112, 125, 138, 150, 162, 175, 188, 200, 212, 225, 238, 250.
2. Specify all lengths in even .06 inch increments. For minimum lengths, see charts for specific part number.
3. When pad is specified, pad width will be same as strap width.

* Order one of each assembly to make a complete strap unit or see ordering note on cover.

WEIGHT DATA

2300 SERIES STRAP WEIGHT GRAPH

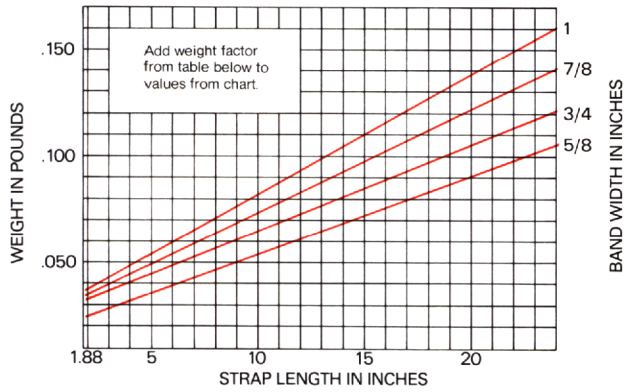

2400 SERIES STRAP WEIGHT GRAPH

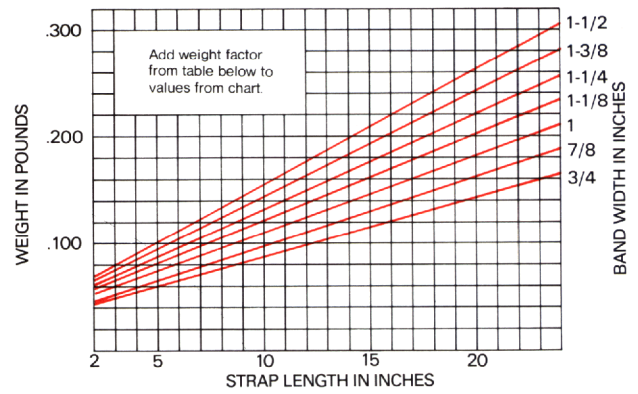

Strap Series	Weight Factor* Due To Component Hardware—Lbs.
2300	+ .000
2301	.025
2302	.017
2303	.029
2304	.021
2305	.003
2330; 32	.010
2331; 33	.028
2334; 36	.027
2335; 37	.032
2338; 40	.031
2339; 41	.012
2360	.009
2361	.034
2362	.008
2363	.033
2364	.026
2365	.038
2366	.025
2367	.037
2368	.030
2369	.011
2370	.029
2371	.010

Strap Series	Weight Factor* Due To Component Hardware—Lbs.
2400	+ .024
2401	.075
2402	.053
2403	.088
2404	.064
2405	.000
2430; 32	.047
2431; 33	.098
2434; 36	.076
2435; 37	.111
2438; 40	.087
2439; 41	.023
2460	.045
2461	.096
2462	.041
2463	.092
2464	.075
2465	.109
2466	.070
2467	.105
2468	.086
2469	.022
2470	.081
2471	.017

*All weights are figured less pad. For weight of assembly with pads, consult Aeroquip.



Aerospace Group

300 S. East Avenue, Jackson, MI 49203-1972

Phone: 517-787-8121, Telex: 223412, Fax: 517-787-5758

A TRIUNOVA Company

AEROQUIP CORPORATION / MAUMEE, OHIO, U.S.A. 43537

Specifications subject to change without notice / Aeroquip products are protected by patents internationally

Aeroquip products are available around the corner, around the world